

INSTALLATION BP2.EU

MANUAL

TRAPEZOIDAL SHEETS

T50/T55/T62/
T80/T90/T135/
T153/T160

INSTALLATION MANUAL FOR TRAPEZOIDAL SHEETS

1. Intended use

Trapezoidal sheets manufactured by BLACHPROFIL 2 Sp. z o.o. can be used to make covers, roofing, and external wall cladding. The use and method of production of enclosures made from BLACHPROFIL 2 sheets should conform to the technical designs prepared taking into account the applicable standards and technical and construction regulations, as well as the recommendations presented in the relevant instruction.

2. Transport

Transport should be carried out using vehicles suitable for this purpose. The vehicle should have an opening load bed to facilitate loading and unloading. The length of the load bed should be suitable for the size of the sheets to be ordered (the sheets should not extend over the side of the load bed). The sheets must be secured to prevent their displacement during transport.

3. Storage

Unloading should be carried out using specialized mechanical equipment, such as a crane or a forklift with a wide fork spacing. It is prohibited to slide one sheet on another, as well as on other surfaces. If there are abrasions and scratches, they must be secured with touch-up paint that matches the color of the sheet metal. Sheets should not be stored in packages outdoors or in spaces with high humidity and frequent temperature changes. Sheets should be stored in dry and airy spaces. Sheet packages should be laid on wooden or Styrofoam spacers that ensure unrestrained air circulation. Coated sheets in factory packaging should not be stored for more than 3 weeks from their production date. After that time, the packaging should be cut and the sheets should be separated with spacers to allow unobstructed air circulation. The packages should be laid with a slope so that water can freely flow on their surface in case of dampness. The maximum duration of storage should not exceed 5 months from the date of production.

Following these rules will protect the sheets from damage to the organic coating and corrosion. As the manufacturer, BLACHPROFIL 2 does not accept responsibility for corrosion on metal sheets stored in a manner inconsistent with the above rules.

4. Cutting

At the time of delivery to the customer, the dimensions of the trapezoidal sheets are equal to those specified in the purchase order. If additional processing of the sheets is required at the construction site, it is recommended to use traditional hand shears, nibblers, or a hand circulating saw with a special blade which causes no thermal effect (sudden increase in temperature).

Tools that cause a thermal effect, e.g. angle grinders, are not allowed as they can cause damage to the organic and zinc coating, which results in a corrosion process. As the manufacturer, BLACHPROFIL 2 recommends protecting all cut edges with touch-up paint, including at the factory cutting site.

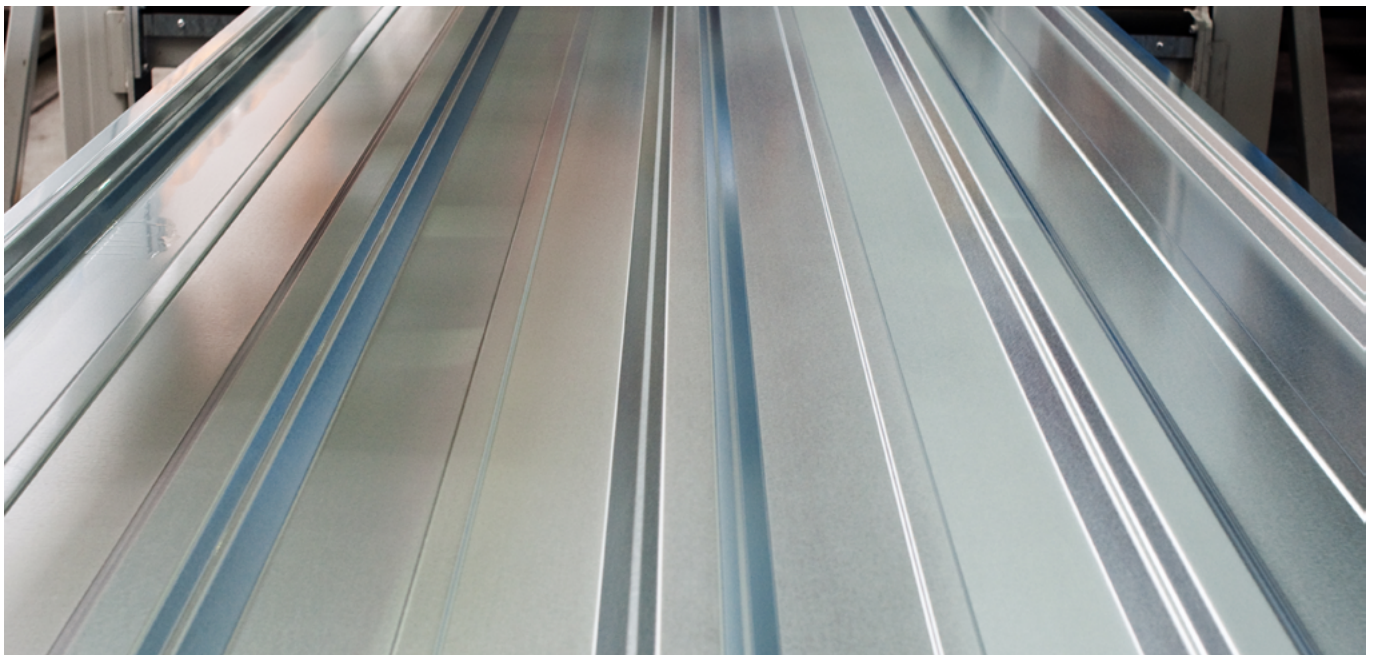

5. Installation

The sheets are fastened to structural elements, such as battens, purlins, or roof rafters and wall rafters by means of self-drilling, self-tapping screws or with nail guns. The fastener is placed in each lower fold of the sheet (FIG. 1 and 2). The spacing of the supports and the number and selection of the fasteners should result from the structural design taking into account the load conditions in which the sheet will be used.

FIG 1. Example of a fastener layout. Isolated roof (POSITIVE sheet placement).

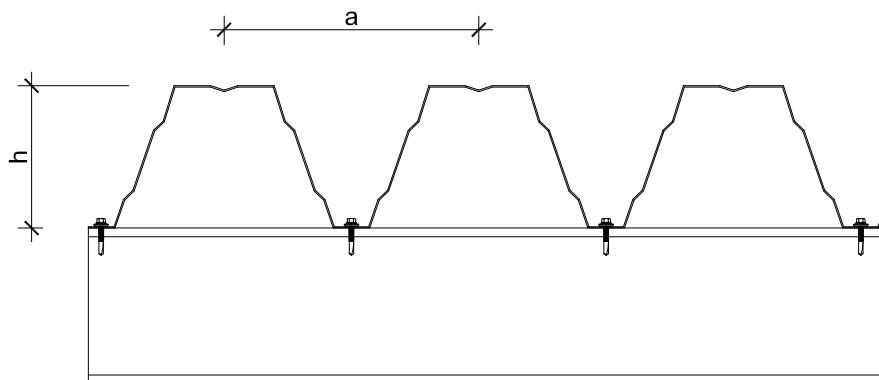
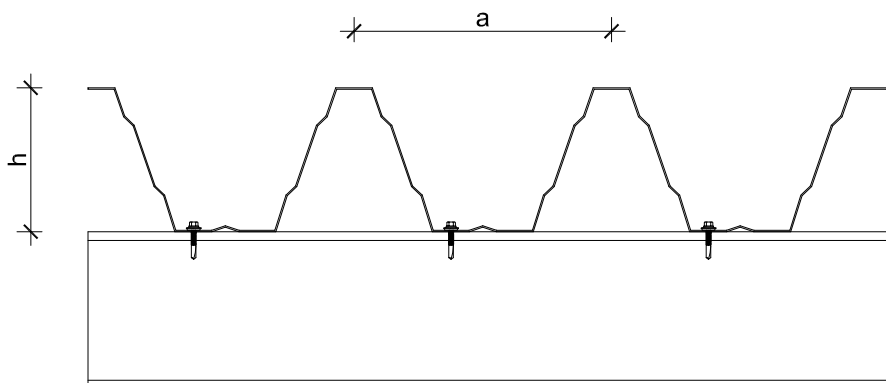

FIG 2. Example of a fastener layout. Non-insulated roof (NEGATIVE steel placement).



The overlap along the length of the sheet (for roofs where the sheet is the top layer of the roof cover) may be made taking into account the conditions shown in Fig. 3.

FIG 3. Example of the size of a sheet overlap depending on the angle of an uninsulated roof.

The overlap along the length of the sheet (for roofs where the sheet is a load-bearing element for insulation) depends on the width of the support and should be between 150 and 300mm. Mutual sheet connections should be done with at least 1 fastener per wave.

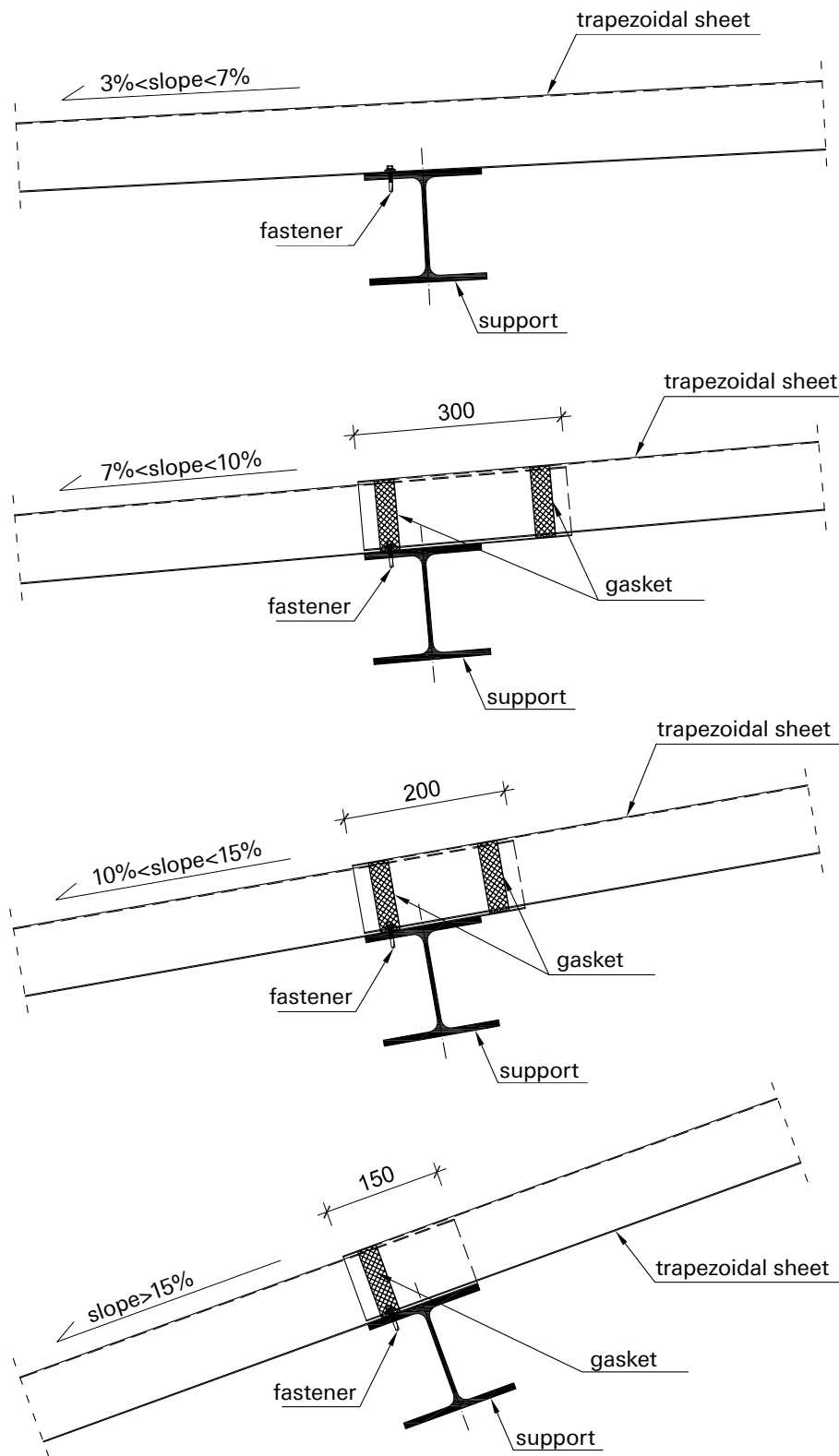

FIG 4. Example of the size of an overlap between the sheets on an insulated roof - sheet installation method with a connection over the intermediate support.

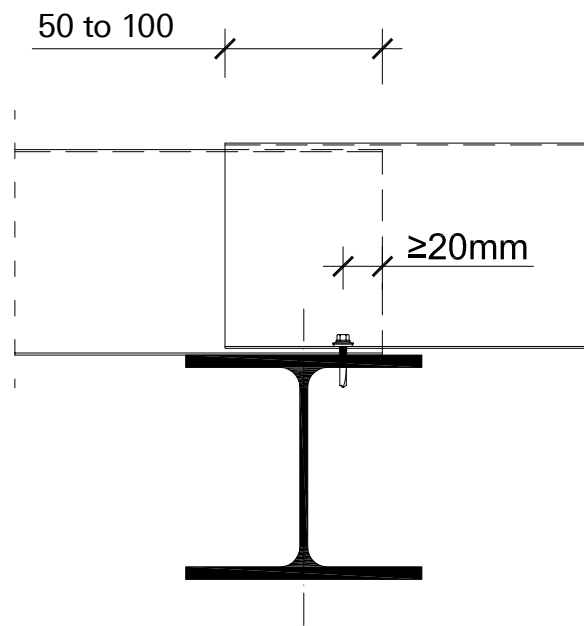
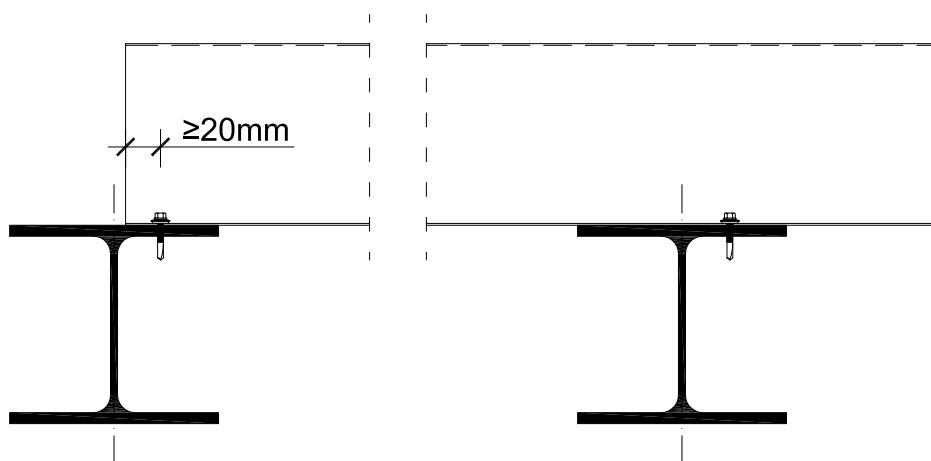

FIG 5. Minimum widths of sheet supports.

Wall	100
Wood	60
Steel/reinforced concrete	40 - profiles $\leq T80$
Steel/reinforced concrete	60 - profiles $\geq T90$



OUTERMOST SUPPORT

INTERMEDIATE SUPPORT

FIG 6. Installation of sheets in a two-span staggered system.

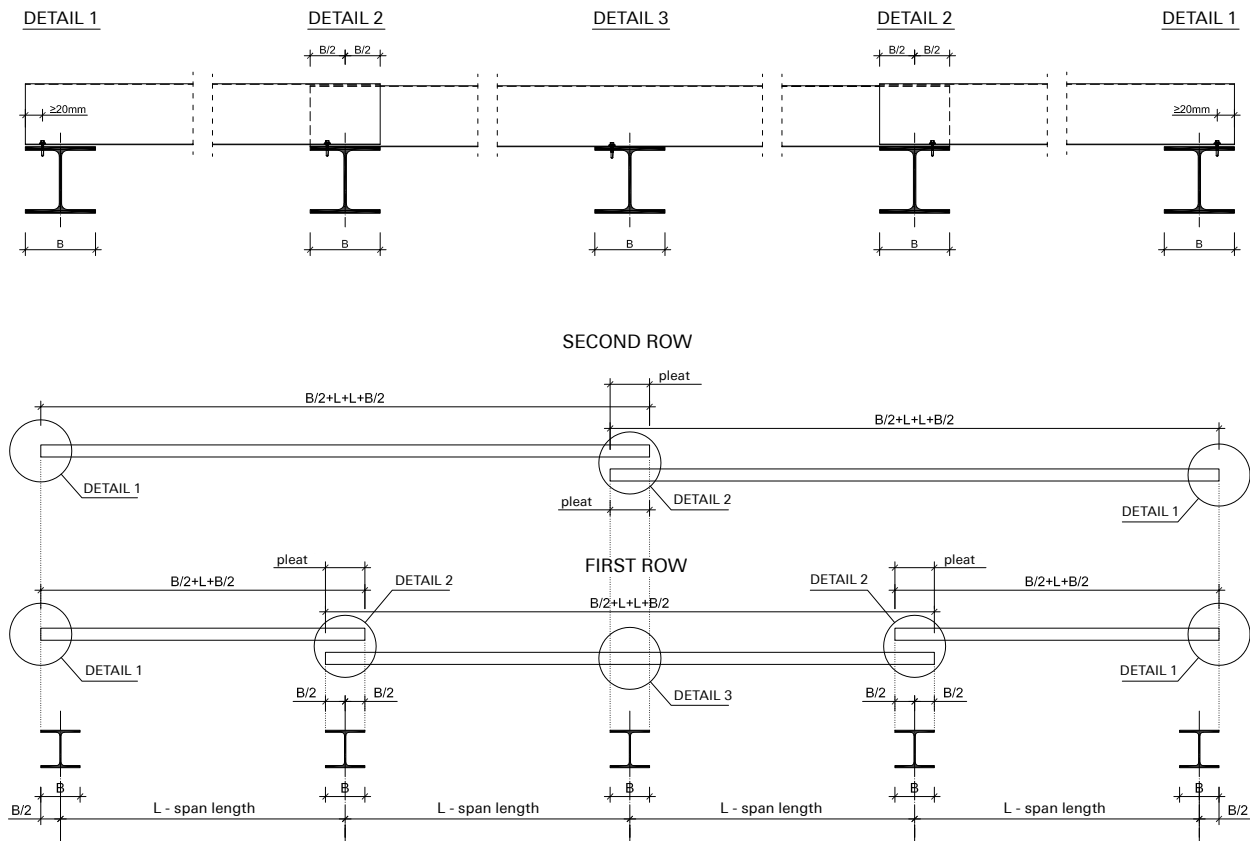
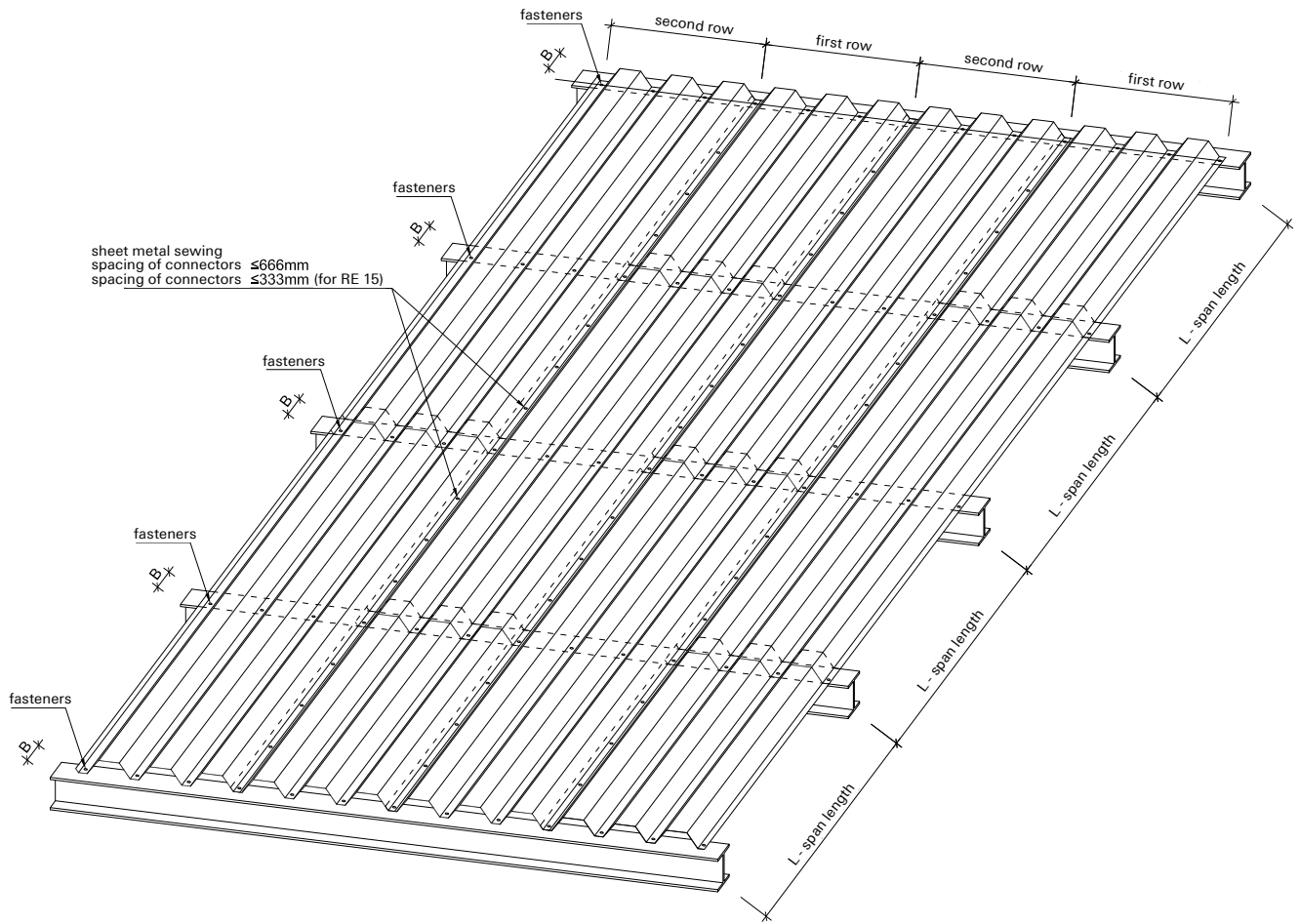
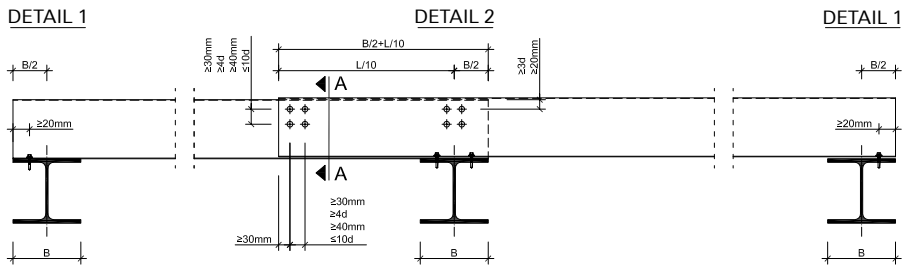
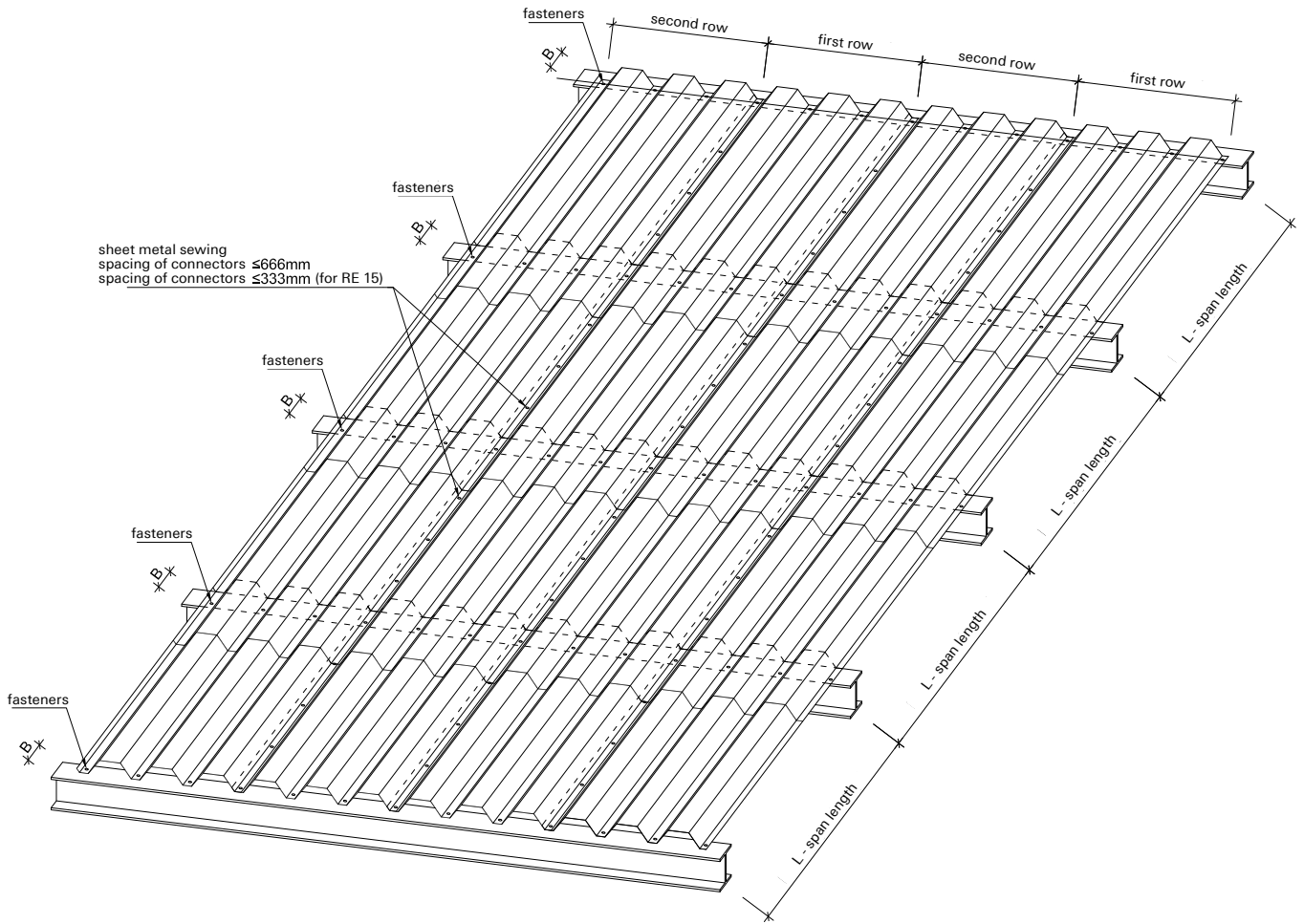

FIG 7. Installation of sheets with a single joint reinforcement over the intermediate support.



CROSS-SECTION A-A

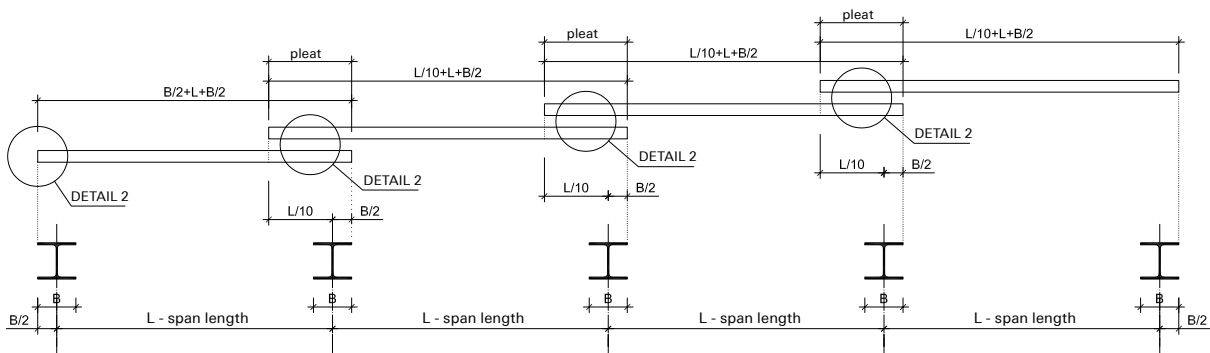
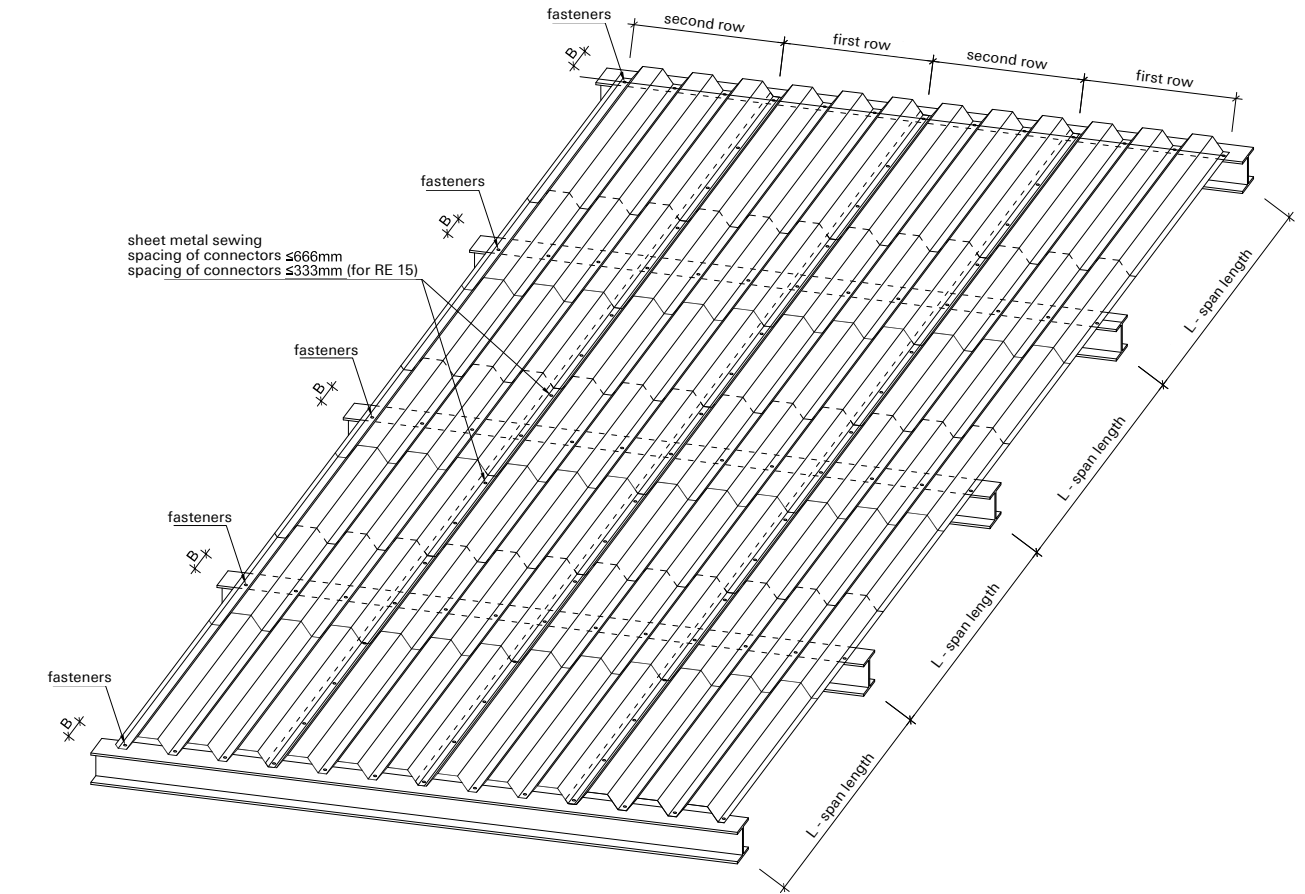

FIG 8. Installation of sheets with a double joint reinforcement over the intermediate support.



DETAIL 1

DETAIL 2

DETAIL 1

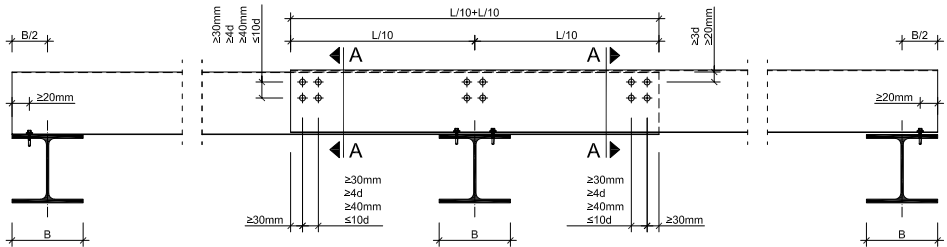

CROSS-SECTION A-A

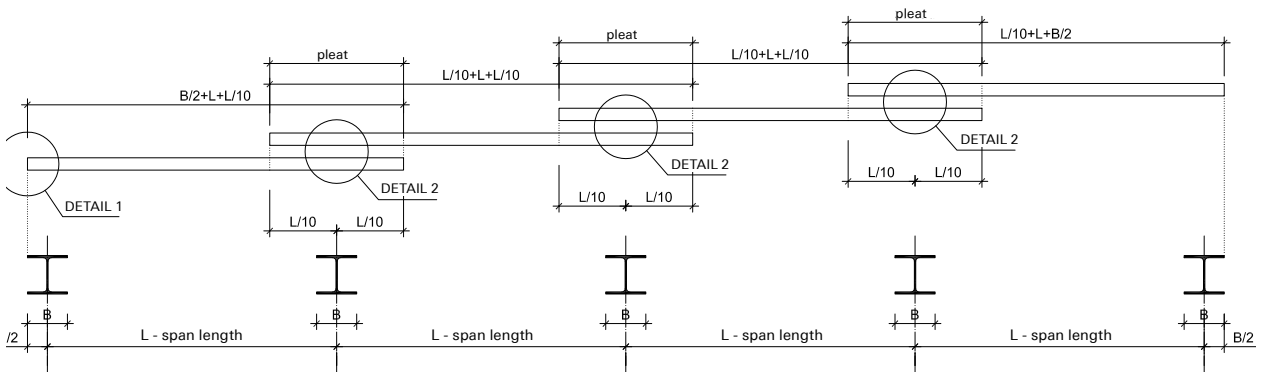

FIG 9. Expansion joint on the roof surface.

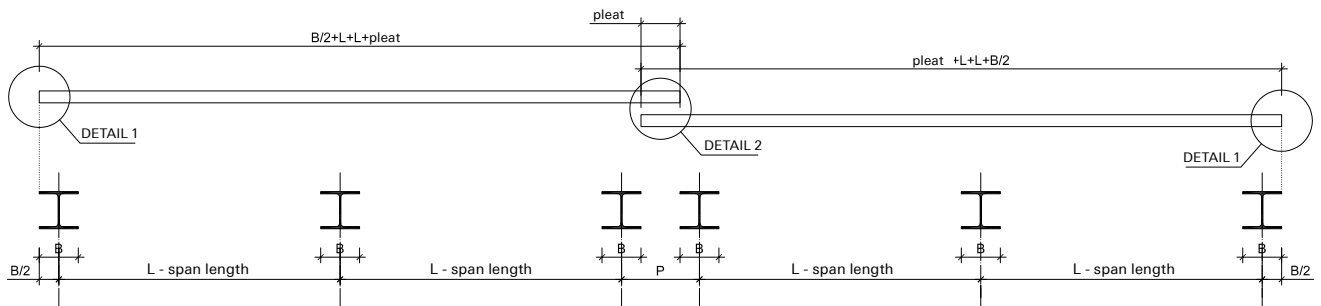
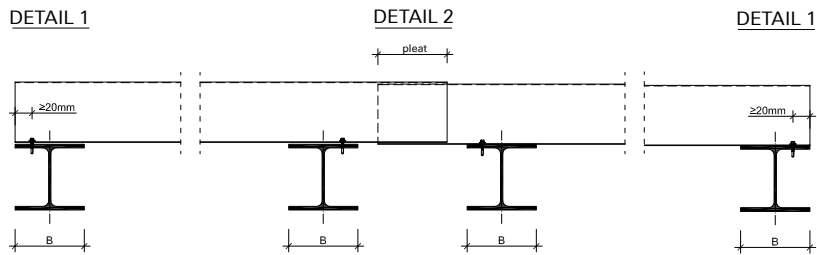
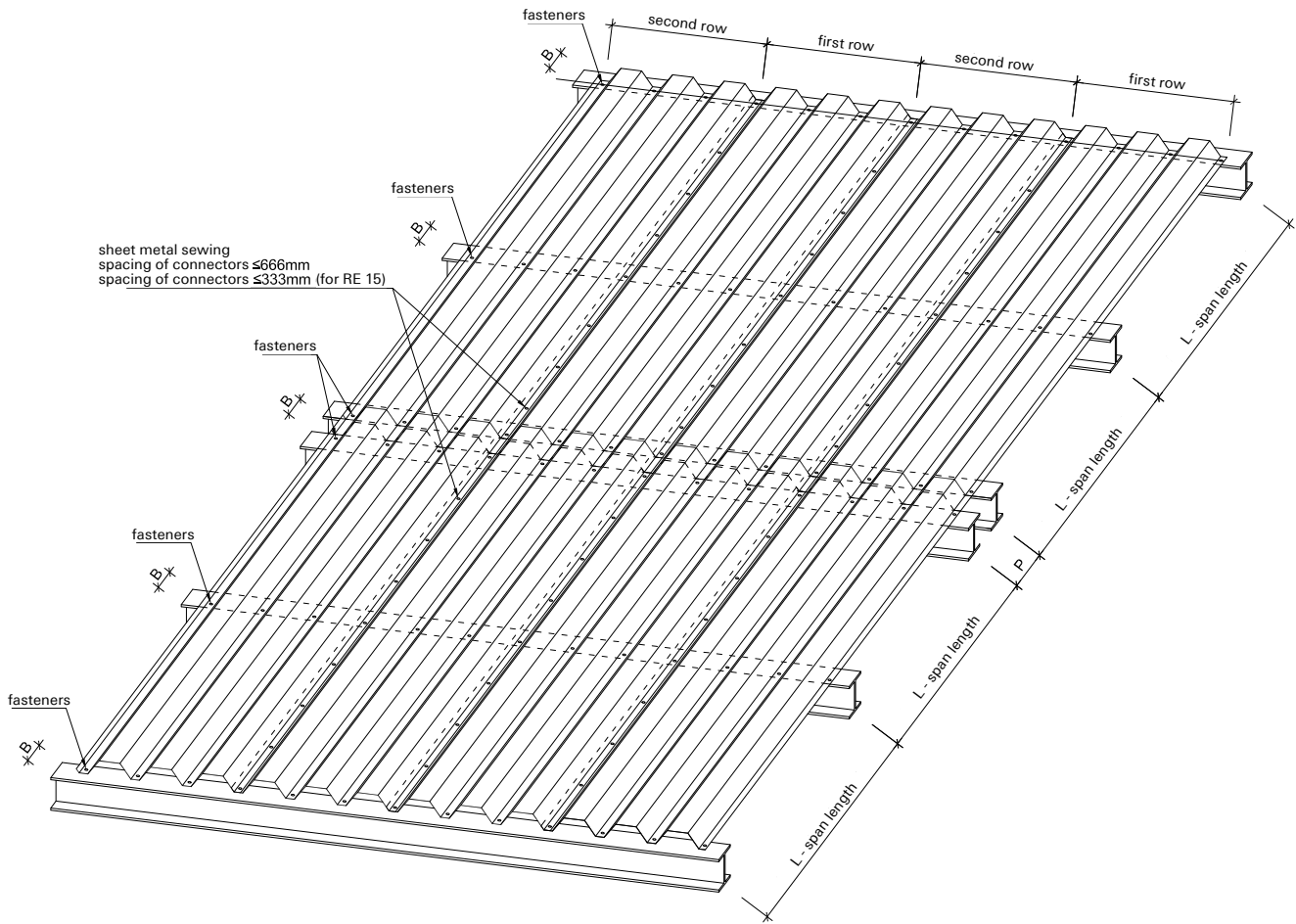

FIG 10. Arrangement of fasteners to ensure fire resistance RE15.

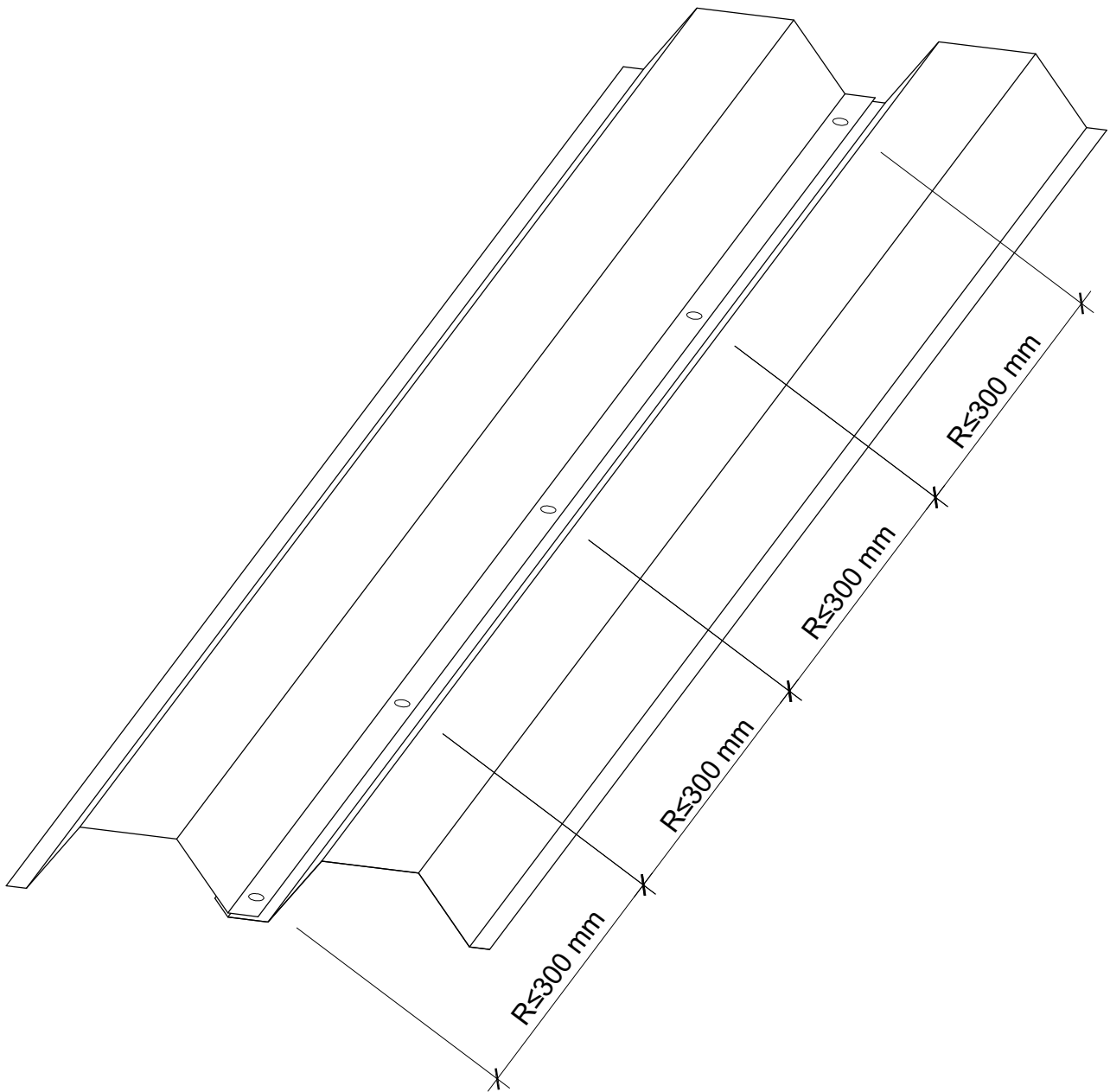
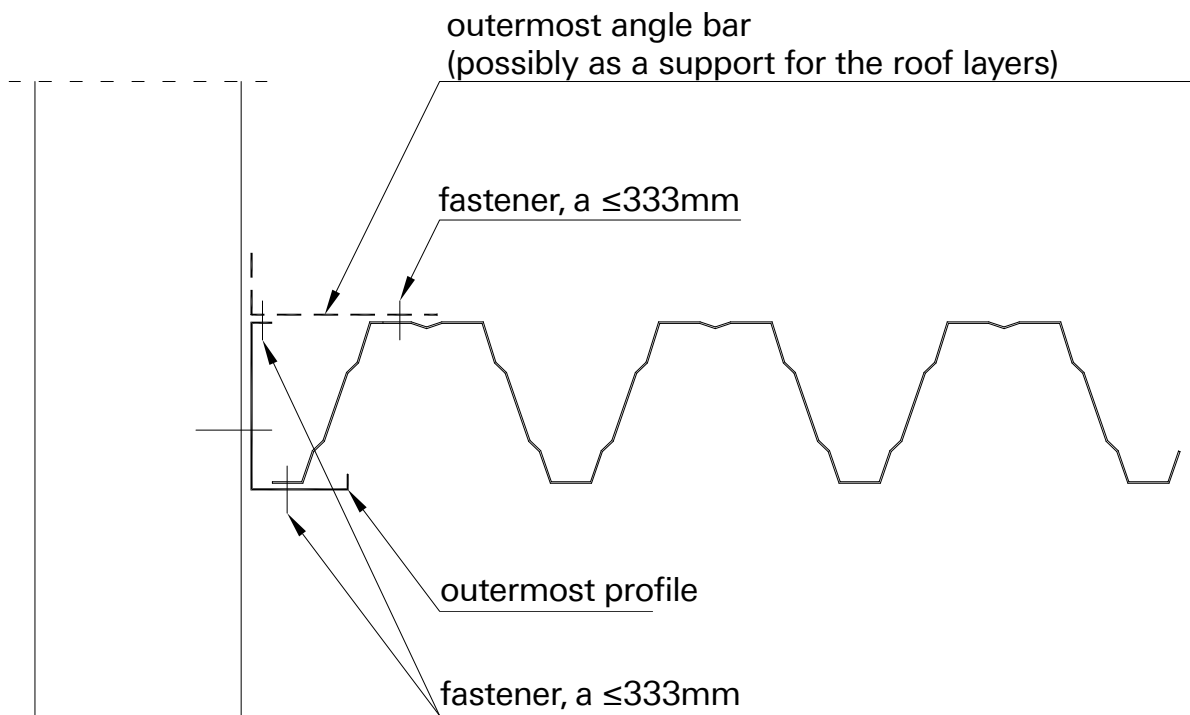
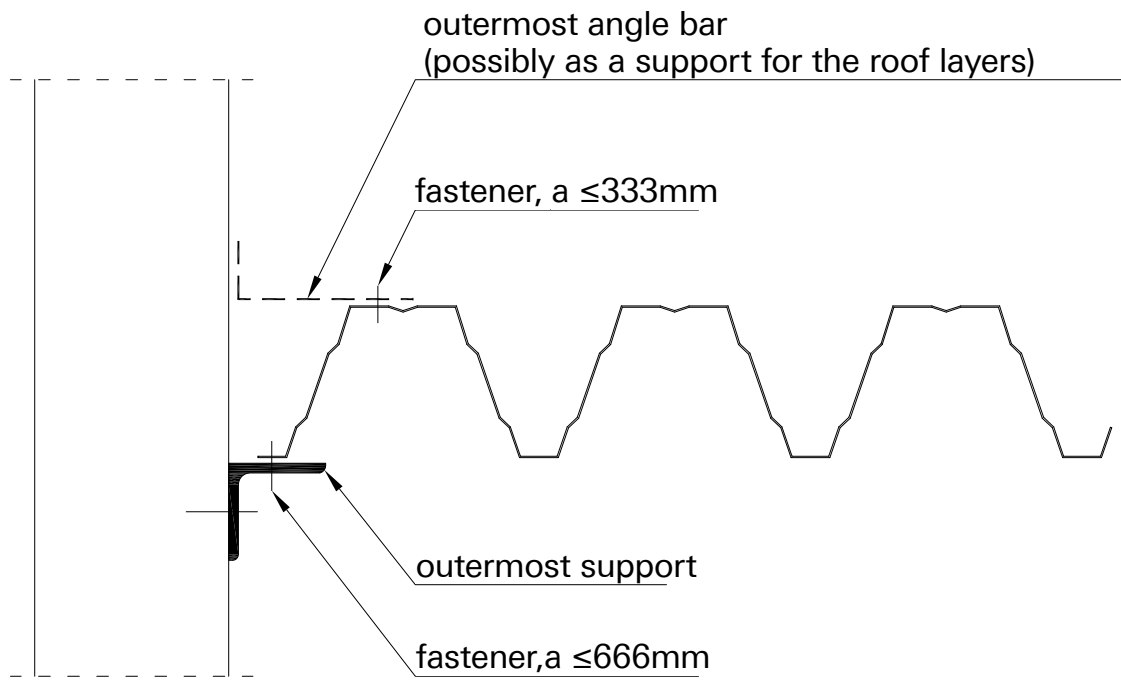
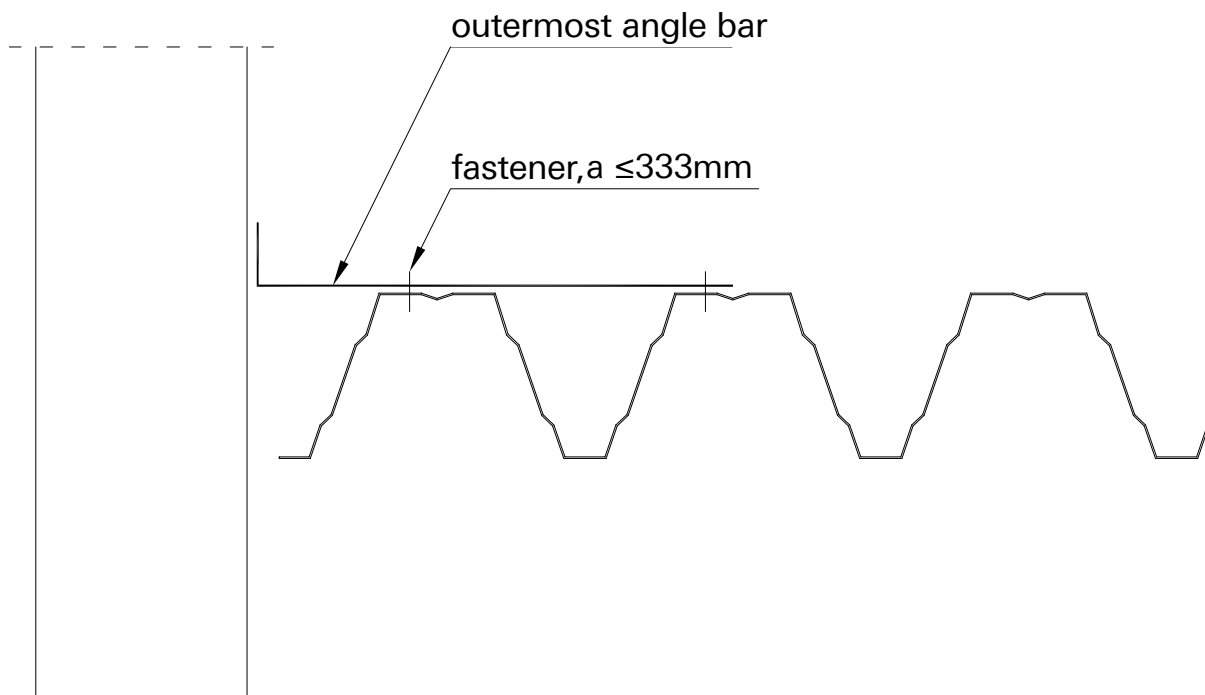
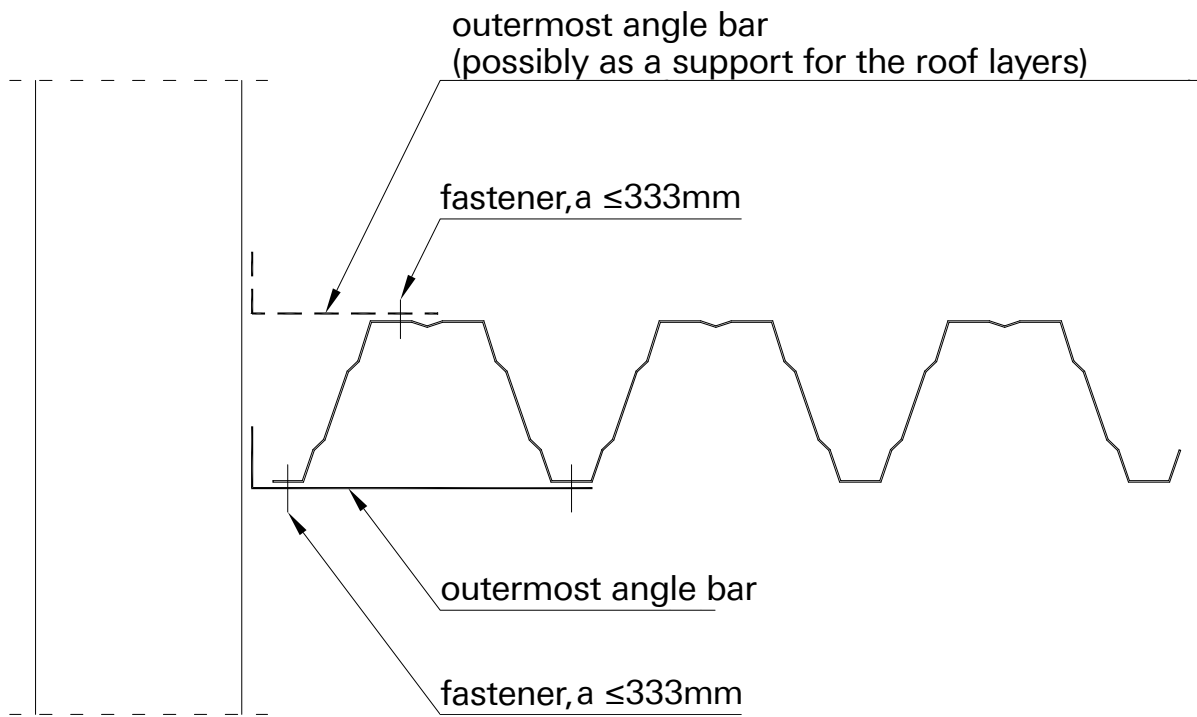

FIG 11. Stiffening the free edge of the sheet - examples.





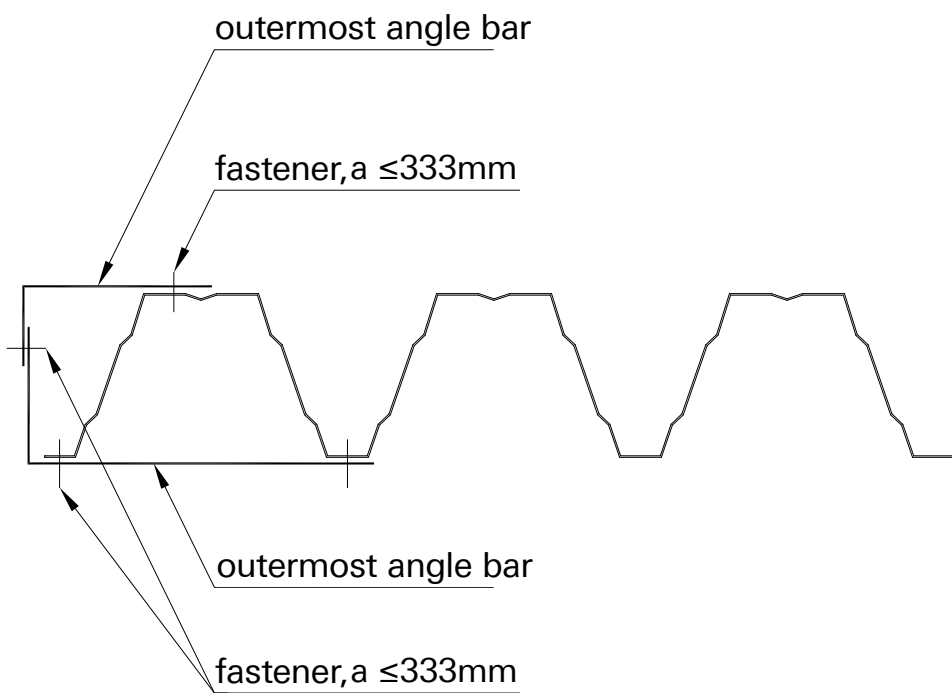
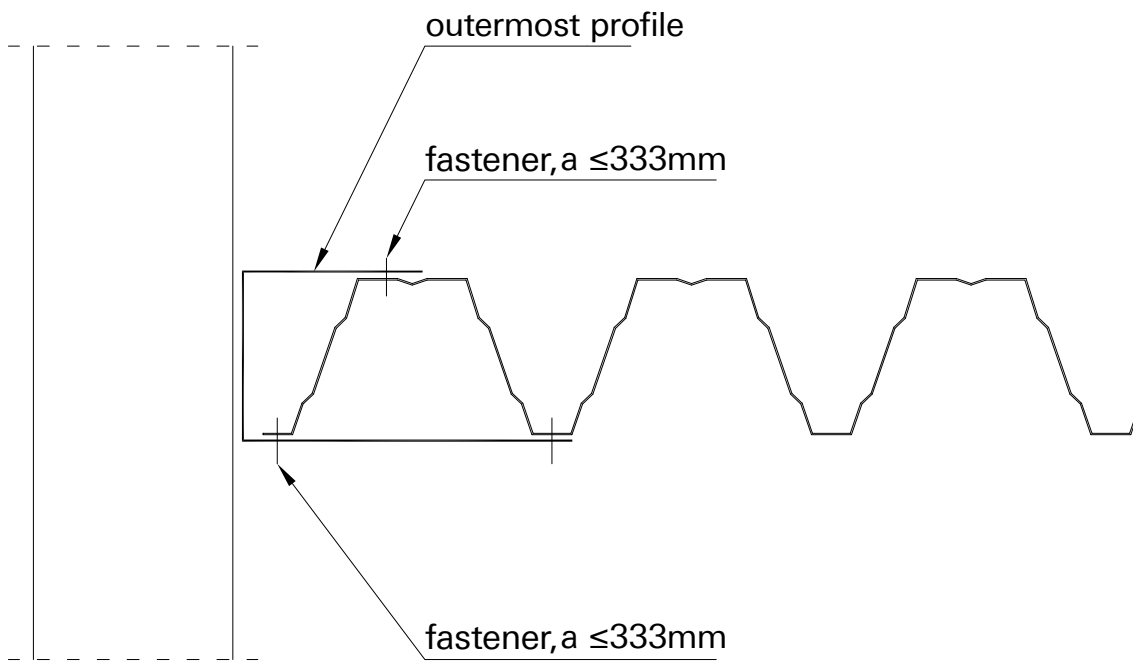

FIG 12. Example diagram of insulated roof layers.

